



# Aerospace

Soluzioni Alberti per Applicazioni Aeronautiche / Alberti Solution for Aerospace Applications

## Ali e deriva / Control surfaces

Turboflex

Svasatore/Rivetting holder

Slimline

TR90cn-0,5

T90cn-0,5XXL

T90cn-0,4 JET INOX

## Carrello / Landing gear

TH90cn-4,5

TA57cn-1,5

TH90cn-1,5

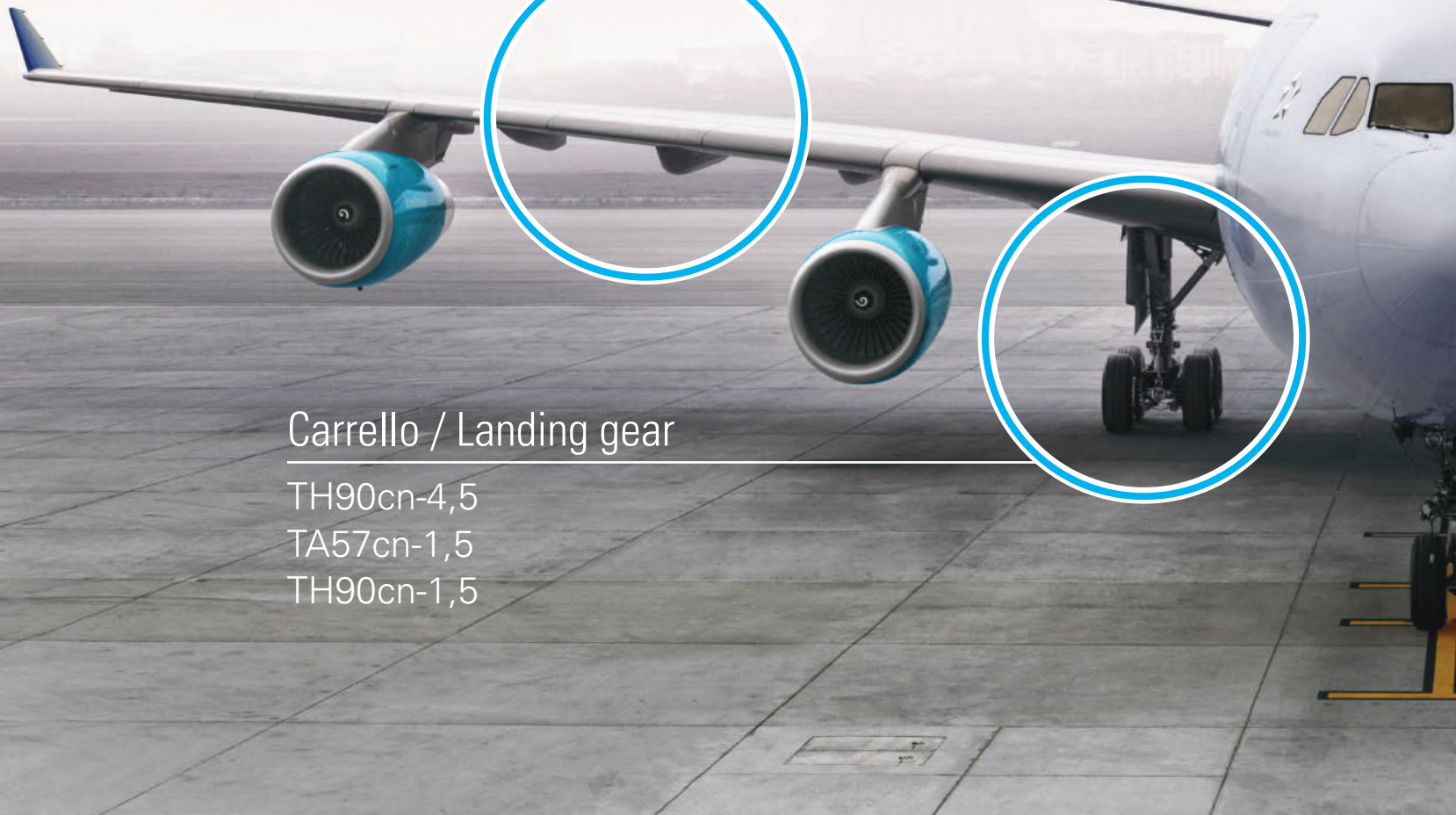



## Fusoliera / Fuselage

Turboflex  
Svasatore/Rivetting holder  
Slimline

## Motore / Engine

T90cn-0,4  
TH90cn-4,5  
TA57cn-1,5  
TA00cn-3,5

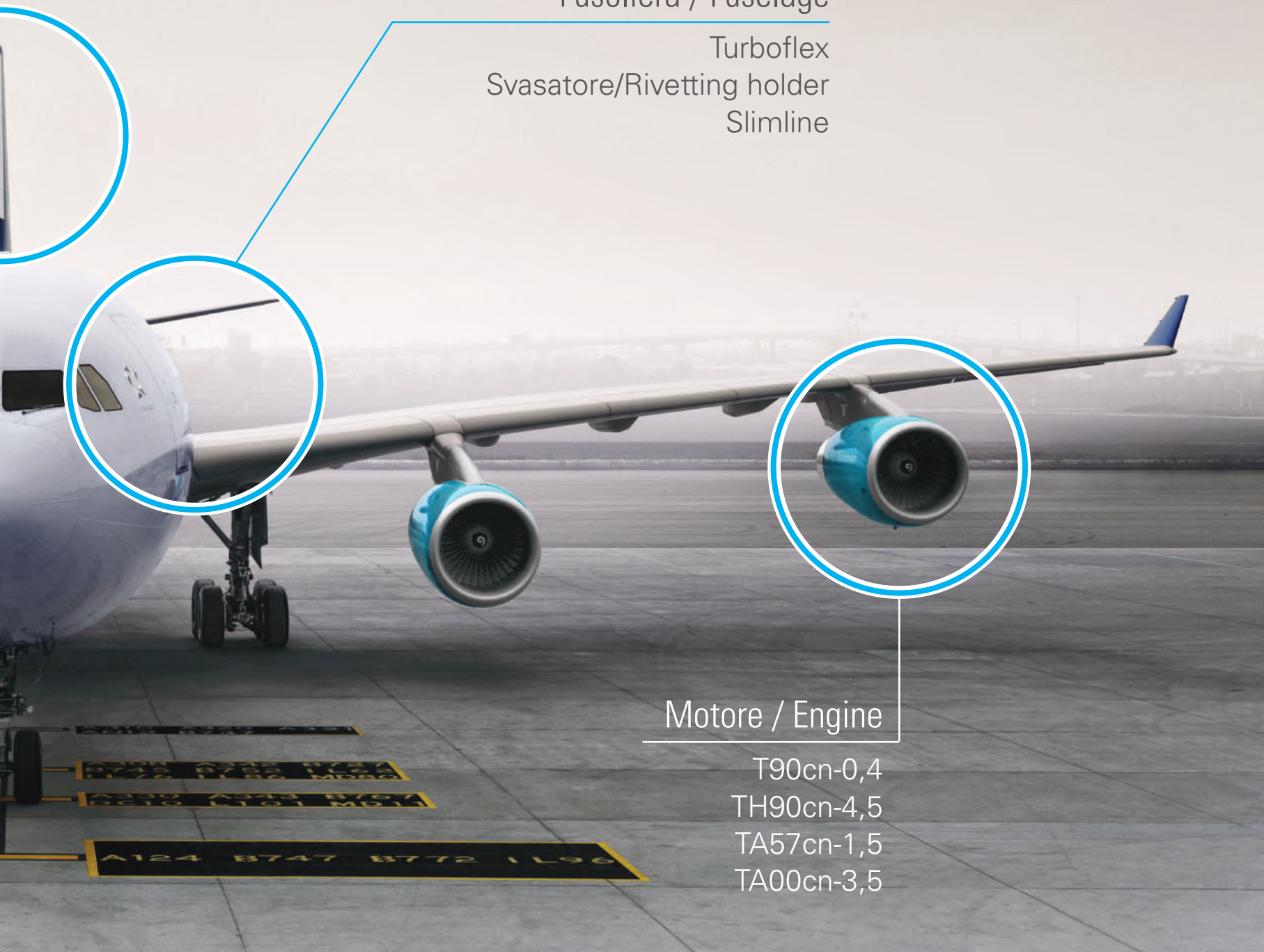

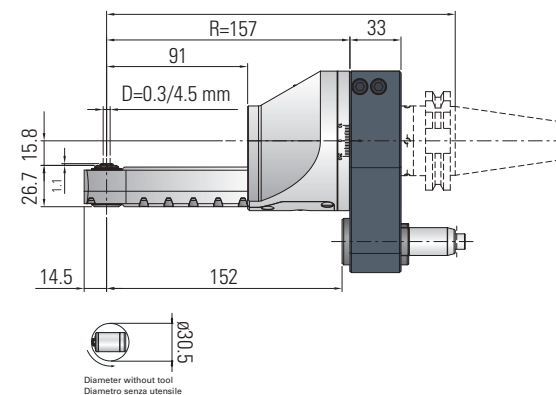
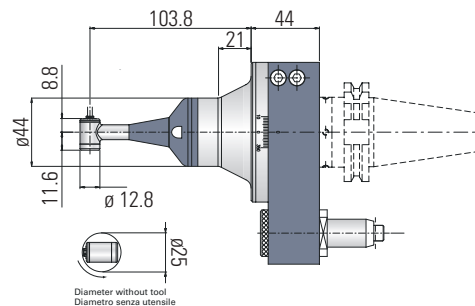
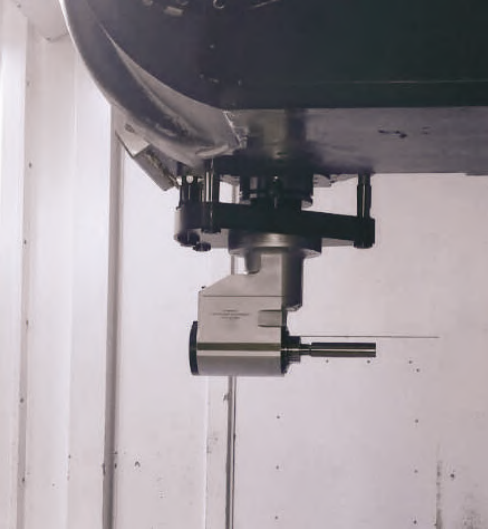

TIPO DI TESTA / TYPE OF HEAD

## Slimline + IC 300

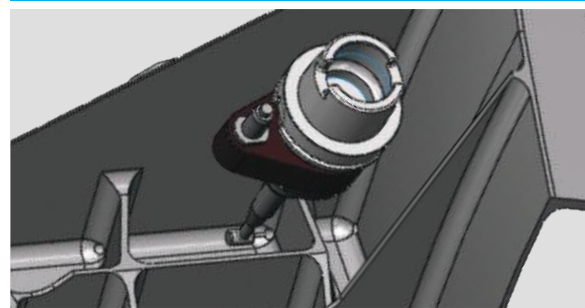

LAVORAZIONE / APPLICATION

**Esecuzione di piccoli fori e contornatura, foratura**  
**Small grooves bores and contouring, drilling**

MATERIALE / MATERIAL

Fibre di carbonio / leghe di Alluminio (2024 - 7075)  
 Carbon fiber / Aluminum alloy (2024 - 7075)

PINZA / CUTTER: Max. 3mm

### Dati Tecnici / Technical Data

Rapporto / Ratio		3/4
Max. velocità / RPM max.	min <sup>-1</sup>	11.000
Peso / Weight	kg	3

Disponibile con altri manipoli  
 Available with other output spindle

TIPO DI TESTA / TYPE OF HEAD

## TR90cn-05

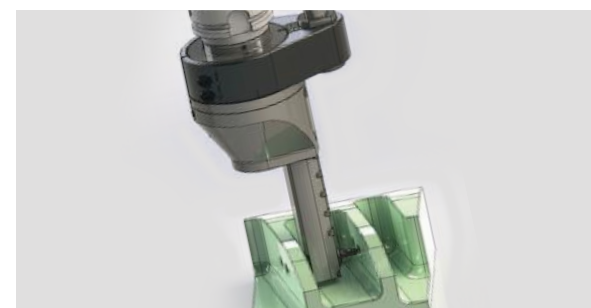

LAVORAZIONE / APPLICATION

**Foratura e fresatura**  
**Drilling and milling**

MATERIALE / MATERIAL

Leghe di alluminio / compositi  
 Aluminum alloy / composites

PINZA / COLLET: Max. 4,5mm

### Dati Tecnici / Technical Data

Rapporto / Ratio		2.4:1
Max. velocità / RPM max.	min <sup>-1</sup>	3.500
Max. carico assiale / Max. axial load	N	135
Momento torcente / Torque	Nm	8
Peso / Weight	kg	4,5

Disponibile in altre dimensioni  
 Available in other sizes

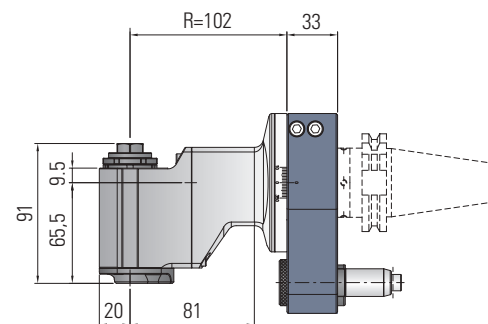
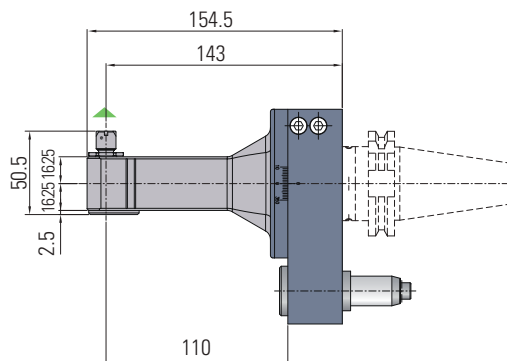
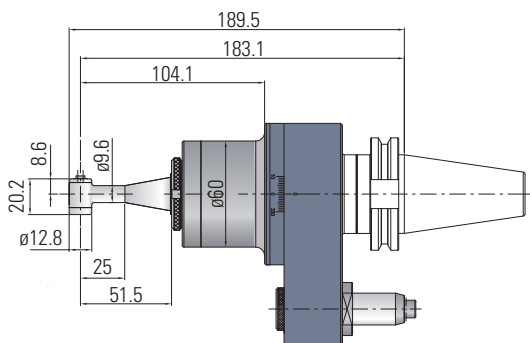

TIPO DI TESTA / TYPE OF HEAD

## Turboflex Index + IC 300

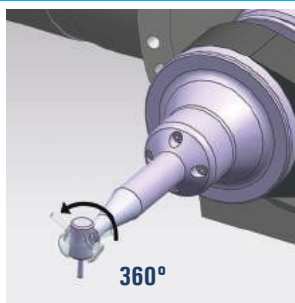
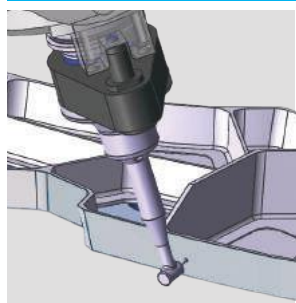

360°

LAVORAZIONE / APPLICATION

**Fori pilot adiacenti a pareti**  
*Pilot holes close to surface frame*

AIR  
DRIVEN  
UNIT

MATERIALE / MATERIAL

Titanio / leghe di Alluminio (2024 - 7075)  
Titanium / Aluminum alloy (2024 - 7075)

PINZA / COLLET: Max. 3mm

### Dati Tecnici / Technical Data

Rapporto / Ratio		3/4
Max. velocità / RPM max.	min <sup>-1</sup>	30.000
Pressione aria / Air pressure	bar	max. 6 (max. 90 Psi)
Peso / Weight	kg	4

TIPO DI TESTA / TYPE OF HEAD

## T90cn-0,4 JET INOX

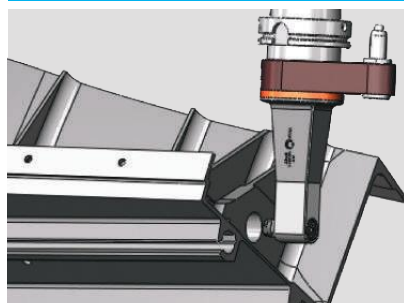

LAVORAZIONE / APPLICATION

**Foratura e fresatura in piccoli spazi**  
*Drilling and milling in confined spaces*

STAINLESS  
STEEL  
UNIT

MATERIALE / MATERIAL

Leghe di Alluminio (2024 - 7075)  
Aluminum alloy (2024 - 7075)

PINZA / COLLET: ER8 (Ø 0.5-5mm)

### Dati Tecnici / Technical Data

Rapporto / Ratio		1:1
Max. velocità / RPM max.	min <sup>-1</sup>	10.000
Max. carico assiale / Max. axial load	N	60
Momento torcente / Torque	Nm	4
Peso / Weight	kg	4

Disponibile in altre dimensioni  
Available in other sizes

TIPO DI TESTA / TYPE OF HEAD

## TH90cn-1,5 100 Bar

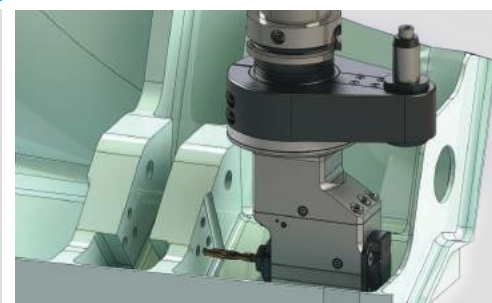

LAVORAZIONE / APPLICATION

**Foratura, barenatura e alesatura**  
*Drilling, boring and reaming*

HIGH  
PRESSURE  
UNIT

MATERIALE / MATERIAL

Leghe di alluminio  
Aluminum alloy

PINZA / COLLET: disponibile con ER-16 / ER25 / ER32 / ER40  
available with

### Dati Tecnici / Technical Data

Rapporto / Ratio		1:1
Max. velocità / RPM max.	min <sup>-1</sup>	10.000
Max. carico assiale / Max. axial load	N	250
Momento torcente / Torque	Nm	15
Peso / Weight	kg	4,5



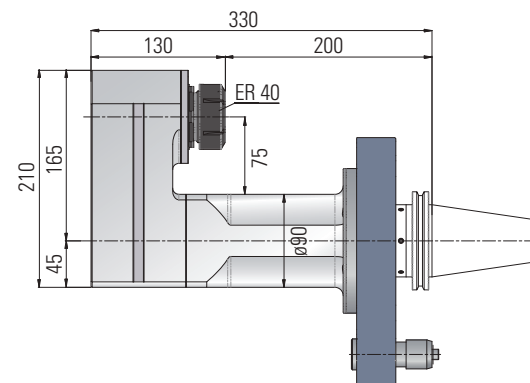
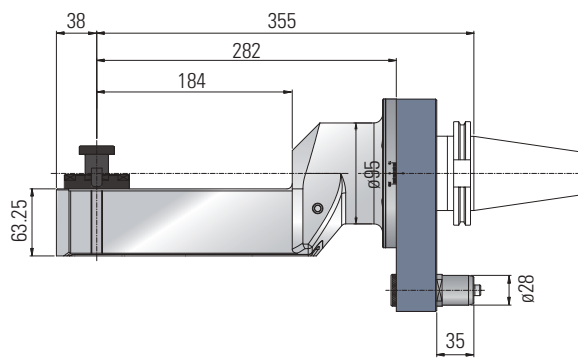
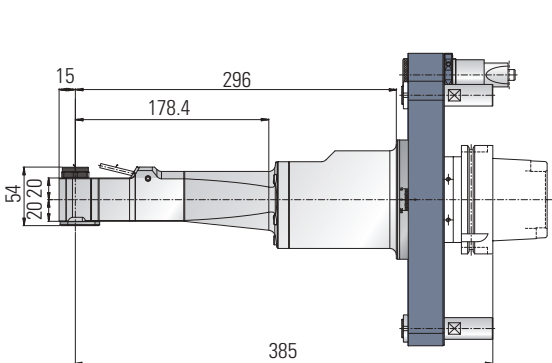

TIPO DI TESTA / TYPE OF HEAD

**T90cn-0,5XXL**

TIPO DI TESTA / TYPE OF HEAD

**TR90cn-4,5**

TIPO DI TESTA / TYPE OF HEAD

**TA00cn-3,5**

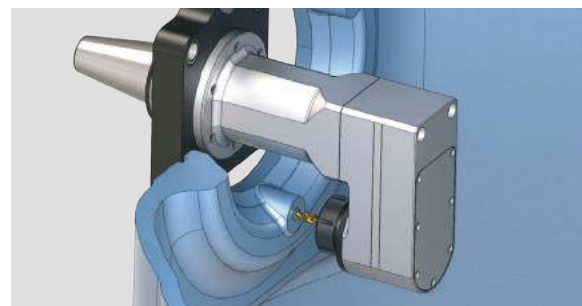
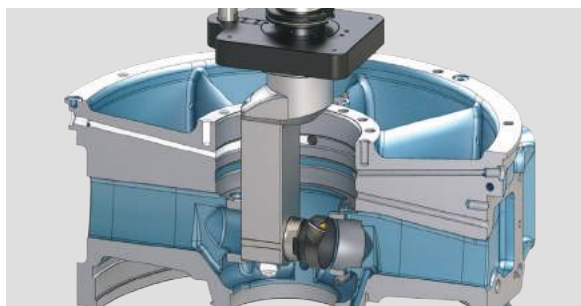
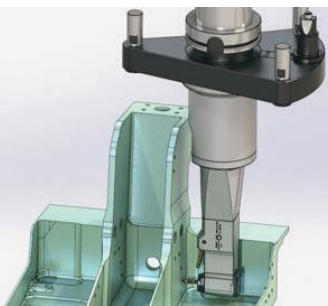

LAVORAZIONE / APPLICATION

**Foratura, fresatura e alesatura**  
**Drilling, milling and reaming**

EXTENDED  
LENGHT  
UNIT

LAVORAZIONE / APPLICATION

**Fresatura e barenatura**  
**Milling and boring**

LAVORAZIONE / APPLICATION

**Foratura e maschiatura**  
**Drilling and Tapping**

U-STYLE  
UNIT

MATERIALE / MATERIAL

Fibre di carbonio / leghe di Alluminio (2024 - 7075)  
Carbon fiber / Aluminum alloy (2024 - 7075)

PINZA / COLLET: ER11 (Ø 0.5-7mm)

**Dati Tecnici / Technical Data**

Rapporto / Ratio		1:1
Max. velocità / RPM max.	min <sup>-1</sup>	6.000
Max. carico assiale / Max. axial load	N	120
Peso / Weight	kg	6,5
Momento torcente / Torque	mm	8Nm

MATERIALE / MATERIAL

Acciaio, titanio e superleghe  
Steel, titanium e superalloy

PINZA / COLLET: ER40 (Ø 3 / ø30)

**Dati Tecnici / Technical Data**

Rapporto / Ratio		1.2:1
Max. velocità / RPM max.	min <sup>-1</sup>	4.000
Max. carico assiale / Max. axial load	N	1.200
Momento torcente / Torque	Nm	75
Peso / Weight	kg	21

Disponibile in altre dimensioni  
Available in other sizes

MATERIALE / MATERIAL

Acciaio, titanio e superleghe  
Steel, titanium e superalloy

PINZA / COLLET: ER32 (Ø 3 / Ø20)

**Dati Tecnici / Technical Data**

Rapporto / Ratio		1:1
Max. velocità / RPM max.	min <sup>-1</sup>	4.000
Max. carico assiale / Max. axial load	N	1750
Momento torcente / Torque	Nm	75
Peso / Weight	kg	18

Disponibile in altre dimensioni  
Available in other sizes

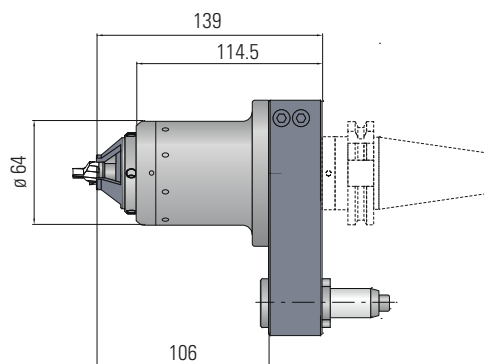
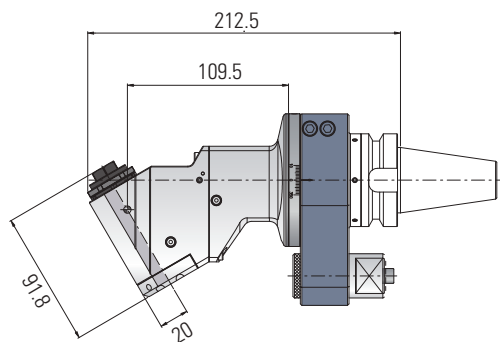

TIPO DI TESTA / TYPE OF HEAD

TH57cn-1,5

TIPO DI TESTA / TYPE OF HEAD

Svasatore / Rivetting holder

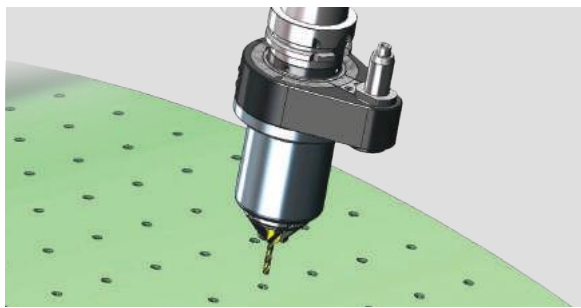
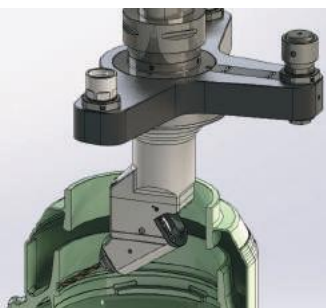

LAVORAZIONE / APPLICATION

**Foratura, fresatura e maschiatura**  
**Drilling, milling and Tapping**



LAVORAZIONE / APPLICATION

**Foratura e svasatura su superfici a profilo variabile**  
**Drilling and countersinking on uneven surfaces**

MATERIALE / MATERIAL

Titanio e superleghe  
Titanium e Superalloy

PINZA / COLLET: disponibile con ER-16 / ER25 / ER32 / ER40  
available with

**Dati Tecnici / Technical Data**

Rapporto / Ratio		1:1
Max. velocità / RPM max.	min <sup>-1</sup>	8.000
Max. carico assiale / Max. axial load	N	250
Momento torcente / Torque	Nm	15
Peso / Weight	kg	4,5

MATERIALE / MATERIAL

Titanio / leghe di Alluminio (2024 - 7075) / Compositi  
Titanium / Aluminum alloy (2024 - 7075) / Composites

MAX. DIAM. SMUSSO / MAX. CHAMFER:  $\varnothing 16$

**Dati Tecnici / Technical Data**

Rapporto / Ratio		1:1
Max. velocità / RPM max.	min <sup>-1</sup>	8.000
Max. carico assiale / Max. axial load	N	480
Peso / Weight	kg	5

Sistema a compensazione integrata  
Integrated spring-loaded mechanism

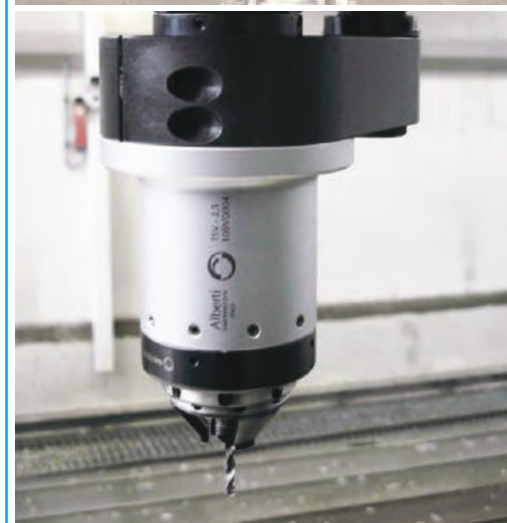

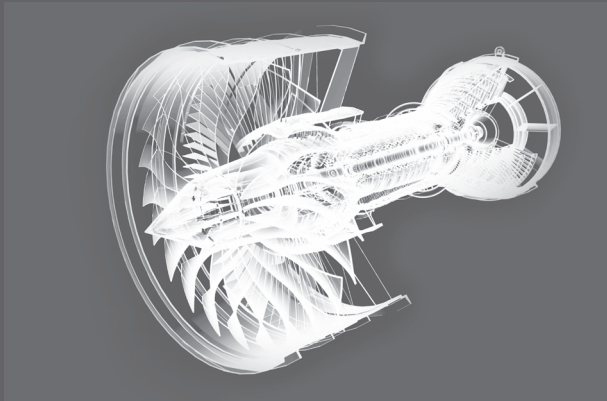

Il nostro ufficio tecnico offre soluzioni speciali ad hoc per ogni tipo di applicazione

Our technical department offers customised solutions for each application.

[www.albertiumberto.com](http://www.albertiumberto.com)

LAVORIAMO CON  
*OUR REFERENCE PARTNERS*

<i>ACITURRI</i>	<i>KAWASAKI HEAVY INDUSTRIES</i>
<i>AERNNOVA</i>	<i>LMI AEROSPACE</i>
<i>AGUSTA WESTLAND</i>	<i>LOCKHEED MARTIN</i>
<i>AIRBUS</i>	<i>PIAGGIO</i>
<i>ALENIA AERMACCHI</i>	<i>PILATUS</i>
<i>AVIO</i>	<i>PRATT &amp; WHITNEY CANADA</i>
<i>BAE SYSTEM</i>	<i>RUAG AEROSPACE</i>
<i>BF AEROSPACE</i>	<i>ROLLS ROYCE</i>
<i>BOEING</i>	<i>SAM AEROSPACE</i>
<i>BOMBARDIER</i>	<i>SNECMA</i>
<i>DASSAULT</i>	<i>SPIRIT AEROSPACE</i>
<i>EMBRAER</i>	<i>SUKHOI AVIATION</i>
<i>GE</i>	<i>TAI AIRLINES</i>
<i>GOODRICH</i>	<i>TAL AEROSPACE</i>
<i>GKN</i>	



Via Gorizia 37  
21047 Saronno (VA)  
Italy  
Tel. +39 02 96 703 586  
Fax +39 02 96 703 620  
[info@albertiumberto.com](mailto:info@albertiumberto.com)